

Assessing spatial and nonspatial factors for healthcare access: towards an integrated approach to defining health professional shortage areas

Fahui Wang*, Wei Luo

Department of Geography, Northern Illinois University, DeKalb, IL 60115-2854, USA

Accepted 10 February 2004

Abstract

This research considers both spatial and nonspatial factors in examining accessibility to primary healthcare in Illinois. Spatial access emphasizes the importance of geographic barrier between consumer and provider, and nonspatial factors include nongeographic barriers or facilitators such as age, sex, ethnicity, income, social class, education and language ability. The population and socioeconomic data are from the 2000 Census, and the primary care physician data for the same year are provided by the American Medical Association. First, a two-step floating catchment area method implemented in Geographic Information Systems is used to measure *spatial accessibility* based on travel time. Secondly, the factor analysis method is used to group various sociodemographic variables into three factors: (1) *socioeconomic disadvantages*, (2) *sociocultural barriers* and (3) *high healthcare needs*. Finally, spatial and nonspatial factors are integrated to identify areas with poor access to primary healthcare. The research is intended to develop an integrated approach for defining Health Professional Shortage Areas (HPSA) that may help the US Department of Health and Human Services and state health departments improve HPSA designation.

© 2004 Elsevier Ltd. All rights reserved.

Keywords: Spatial accessibility; Nonspatial factors; Geographic information systems; Healthcare access; Health professional shortage areas

Introduction

Access to healthcare varies across space because of uneven distributions of healthcare providers and consumers (*spatial factors*), and also varies among population groups because of their different socioeconomic and demographic characteristics (*nonspatial factors*). Accordingly, *spatial access* emphasizes the importance of geographic barriers (distance or time) between consumer and provider, whereas *aspatial access* stresses nongeographic

barriers or facilitators such as social class, income, ethnicity, age, sex, etc. (Joseph and Phillips, 1984). Since the 1960s, health policymakers in the United States have attempted to improve healthcare for the citizenry by considering aspects of both spatial and nonspatial factors (Meade and Earickson, 2000, pp. 383–392). Such efforts are exemplified in designations of Health Professional Shortage Areas (HPSA) and Medically Underserved Areas or Populations (MUA/P) by the US Department of Health and Human Services (DHHS) (General Accounting Office (GAO), 1995; Lee, 1991), for the purpose of determining eligibility for certain federal healthcare resources. As the DHHS is considering consolidating the HPSA and MUA/P designations into one system because of their overlapping criteria (US Department of Health

*Corresponding author. Tel.: +1-815-753-6842; fax: +1-815-753-6872.

E-mail addresses: fwang@niu.edu (F. Wang), wluo@niu.edu (W. Luo).

and Human Services (DHHS), 1998), this research focuses on HPSAs, and primary medical care in particular.

A close examination of the criteria for HPSA designations shows that both spatial and nonspatial factors are important (US Department of Health and Human Services (DHHS), 2004). The DHHS designates two major types of HPSAs: geographic areas and population groups.¹ Both use the population to full-time-equivalent primary care physician ratio within a “rational service area” as a primary indicator, e.g., 3500:1 in general. The service area definitions and the need for contiguous area considerations involve spatial factors (e.g., areas within 30 min travel time of each other). The general ratio of 3500:1 may be lowered if an area has unusually high needs for primary care (for geographic-area HPSAs) or if significant economic, linguistic and cultural barriers exist (for population-group HPSAs), implying the need for consideration of nonspatial factors. Indeed, most of the population-group HPSAs are low-income or minority groups.

While researchers are aware of the importance of both spatial and nonspatial factors in assessing healthcare access, often the two types of factors are studied separately. For example, Khan (1992) and Luo and Wang (2003) focused on spatial access to healthcare; Carr-Hill et al. (1994) and Field (2000) emphasized nonspatial factors. Successful integration of spatial and nonspatial factors is critical to design an effective method of assessing healthcare access. Three challenges remain for this task:

- (1) implementing the measure of spatial accessibility in a reasonably simple process;
- (2) aggregating various sociodemographic variables (often correlated) to independent (or uncorrelated) indicators of nonspatial accessibility; and
- (3) integrating spatial and nonspatial factors into one framework for assessing healthcare access and identifying physician shortage areas.

This research intends to address the above three issues. Related literatures will be reviewed in the following sections where methods are discussed. This paper builds upon prior research, and makes contributions in the following ways:

- (1) It uses a *two-step floating catchment area (FCA) method* to measure spatial accessibility based on travel times between residents and physicians. The method is easy to implement in a Geographic Information System (GIS) environment.

¹The DHHS also designates facilities (correctional institutions, youth detention facilities, public or nonprofit private medical facilities) as the third type of HPSAs. Its designation follows very different criteria, and thus not covered by this research.

- (2) It uses the factor analysis (FA) method to consolidate the sociodemographic variables into selected factors, with different loadings that determine whether a factor is used as a primary or secondary indicator for assessing healthcare accessibility.
- (3) It integrates spatial and nonspatial factors into one framework, and identifies the areas and population groups for HPSA designation. The quantitative criteria are consistent, precise and flexible (i.e., more shortage areas may be defined if needed).

Specifically, this paper examines accessibility to primary healthcare in Illinois, based on population census and physician data in 2000. The research is intended to develop an integrated approach for defining physician shortage areas that may help the DHHS and state health departments design a better system for HPSA designation.

Data issues and travel time estimation

The population data are extracted from the 2000 Census Summary File 1 (US Bureau of Census, 2001), and the sociodemographic data are from the 2000 Census Summary File 3 (US Bureau of Census, 2002). The primary care physician data of Illinois in 2000 are based on the Physician Master File of the American Medical Association. Census tract is the lowest areal unit used in the current practice of shortage area designation, and is thus chosen as the analysis unit for population. Physicians are geocoded to zip code areas since many records in the Physician Master File only have “P.O. Box” addresses with zip codes but not street addresses. Zip code represents a finer resolution than county and has been used extensively in health research (e.g., Ng et al., 1993; Parker and Campbell, 1998; Knapp and Hardwick, 2000). There are 2952 census tracts and 1269 zip code areas in Illinois, which are computationally manageable for later travel time estimation by a desktop computer. Spatial data such as coverages of census tracts, census blocks, zip code areas and road networks are all from the data CD-ROMs distributed with ArcGIS by Environmental System Research Institute.²

In this research, population-weighted centroids of census tracts (based on block-level population data) are used instead of simple geographic centroids, to represent population locations more accurately (Hwang and Rollow, 2000). As physicians often choose to practice at populated places, population-weighted centroids of zip code areas were also used to represent physician

²See <http://www.esri.com/data/index.html> for details.

Table 1
Guidelines for travel speed settings

Road category (CFCC) ^a	Population density range (per km ²)		
	< 100 (mph)	(100, 1000) (mph)	≥ 1000 (mph)
Interstate Hwy (A11–A18)	65	55	55
US and State Hwy, some county hwy (A21–A38)	55	45	35
Local roads (A41–A48)	35	25	20

^aThe CFCC (census feature class codes) are used by the US Census Bureau in its TIGER/Line files.

locations.³ This is important particularly in rural or peripheral suburban areas where tracts or zip code areas are large and population tends to concentrate in limited space.

Travel time between any pair of population and physician locations (to be used for measuring spatial accessibility) is estimated by using the Arc/Info network analysis module (Lovett et al., 2002). Travel speeds are often slower in urban areas than suburban or rural areas. After a careful examination of the speed limit maps maintained by the Illinois Department of Transportation, we developed several rules to approximate travel speeds based on the population density pattern (see Table 1 and Fig. 1). Travel time is estimated as the shortest time through road networks between a resident location and a doctor's office.

Measuring spatial accessibility by the two-step floating catchment area method

According to Joseph and Phillips (1984), measures of spatial accessibility include *regional availability* and *regional accessibility*. The former is expressed as a population (demand) to practitioner (supply) ratio within a region, and it is simple and easy to implement. The current HPSA designation system primarily follows this approach. The latter considers complex interaction between supply and demand in different regions based on a gravity kernel, and it is less intuitive and requires more computation.

The regional availability approach has two problems: interaction across regional boundaries is generally not adequately accounted for and spatial variability within a region is not revealed (Wing and Reynolds, 1988). Several methods have been developed to mitigate the problems.

³We geocoded physicians whose full street addresses were available and computed the physician-weighted centroids in 34 zip code areas within which all physician addresses were successfully matched. The mean distance between the physician-weighted centroids and geographic centroids was 2.06 km, whereas the mean distance between the physician-weighted centroids and population-weighted centroids was 1.44 km. It shows that the population-weighted centroid is a better proxy for physician location than the geographic centroid.

For example, some earlier versions of the FCA method were developed for assessing job accessibility (e.g., Peng, 1997). Assuming a threshold travel distance of 15 miles for primary healthcare, a 15-mile circle is drawn around a residential tract as its catchment area. The circle with the same radius (i.e., catchment area) “floats” from the centroid of one tract to another, and the physician-to-population ratio within each tract defines the accessibility there (Luo, 2004). The underlying assumption is that services that fall within the catchment area are fully available to any residents within that catchment. However, not all physicians within the catchment are reachable (given the threshold of 15 miles) by every resident in the catchment, and physicians on the periphery of the catchment may also serve nearby residents outside the catchment and thus not be fully available to residents within the catchment. Wang and Minor (2002) used travel times instead of straight-line distances to define the catchment area, but the fallacies remain.

A method developed by Radke and Mu (2000) overcomes the above fallacies. It repeats the process of “floating catchment” twice (once on physician locations and once on population locations), and is therefore referred to as the “two-step FCA method” in this paper.

First, for each physician location j , search all population locations (k) that are within a threshold travel time (d_0) from location j (i.e., catchment area j), and compute the physician to population ratio R_j within the catchment area:

$$R_j = \frac{S_j}{\sum_{k \in \{d_{kj} \leq d_0\}} P_k}, \quad (1)$$

where P_k is the population of tract k whose centroid falls within the catchment (i.e., $d_{kj} \leq d_0$), S_j is the number of physicians at location j , and d_{kj} is the travel time between k and j .

Next, for each population location i , search all physician locations (j) that are within the threshold travel time (d_0) from location i (i.e., catchment area i), and sum up the physician to population ratios R_j at these locations:

$$A_i^F = \sum_{j \in \{d_{ij} \leq d_0\}} R_j = \sum_{j \in \{d_{ij} \leq d_0\}} \left(\frac{S_j}{\sum_{k \in \{d_{kj} \leq d_0\}} P_k} \right), \quad (2)$$

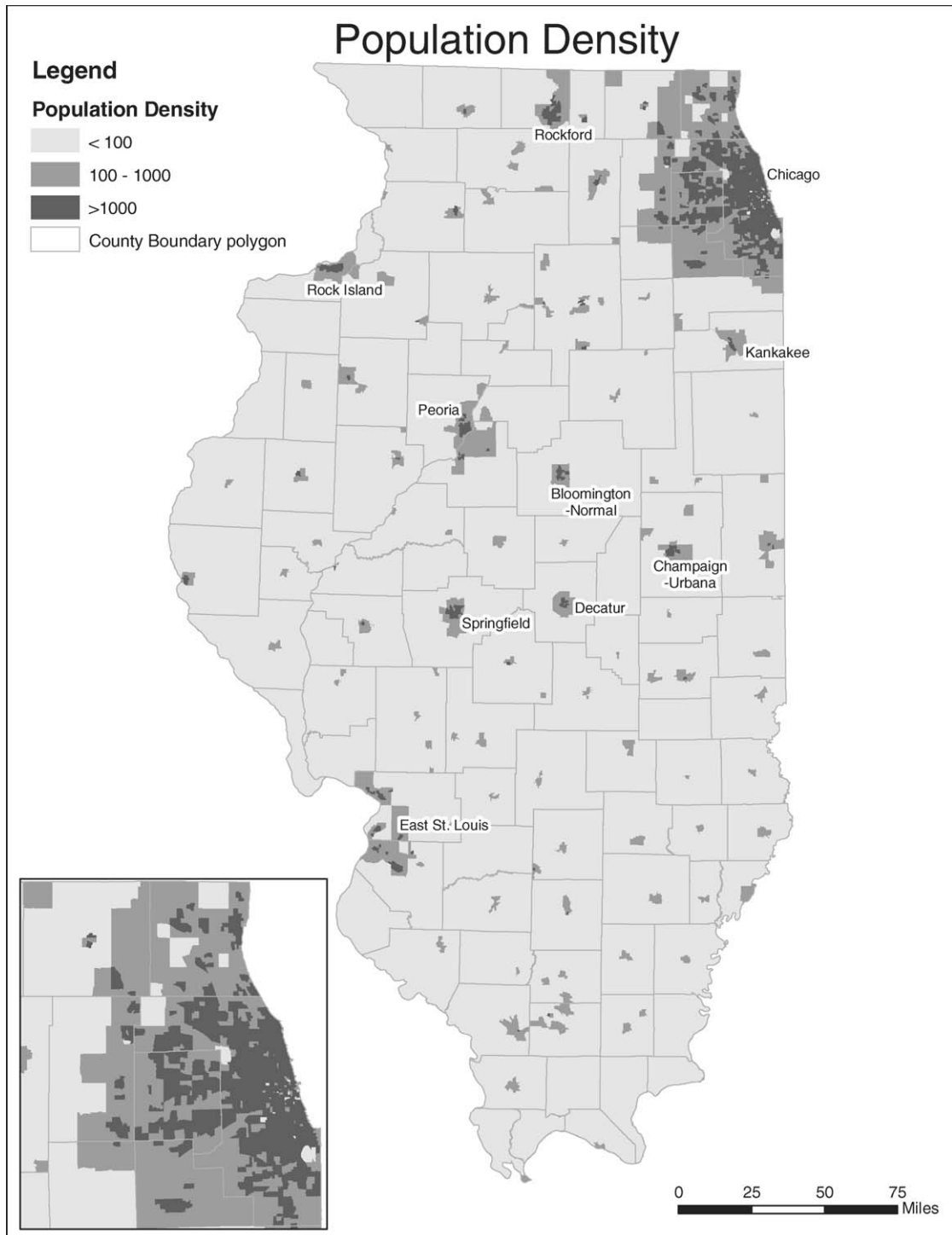

Fig. 1. Population densities in Illinois 2000. Inset shows an enlargement of Chicago area.

where A_i^F represents the accessibility at resident location i based on the two-step FCA method, R_j is the physician-to-population ratio at physician location j whose centroid falls within the catchment centered at i

(i.e., $d_{ij} \leq d_0$), and d_{ij} is the travel time between i and j . In practice, the threshold time may be set at 30 min, which are also used for defining rational service area and determining whether contiguous resources are

excessively distant in the guidelines for HPSA designation (US Department of Health and Human Services (DHHS), 2004). A larger value of A_i^F indicates a better accessibility at a location.

The first step above assigns an initial ratio to each service area centered at a physician location (also considered a measure of physician availability for the supply location), and the second step sums up the initial ratios in the overlapped service areas to measure accessibility for a demand location, where residents have access to multiple physician locations. The method considers interaction between patients and physicians across administrative borders based on travel times, and computes an accessibility measure that varies from one tract to another. Eq. (2) is basically the ratio of physician to population (filtered by a threshold travel time), and thus can be interpreted the same way.

The method can be implemented in GIS (illustrated in ArcGIS here) by the following procedures using a series of “join” and “sum” functions (see Fig. 2).

- (1) A matrix of travel times between physician location (zip code area) and population location (census tract) is computed. The table (say, named *TIME30*) only includes those trips within the threshold time (e.g., 30 min) by setting a search

radius in the network travel time computation command.

- (2) Tables of physicians (say, *DOCZIP*) and population (say, *POPTRT*) are then “joined” to the table *TIME30* by corresponding zip code areas and census tracts, respectively.
- (3) Based on the updated *TIME30*, a new table (say, *DOCAVL*) is generated by “summing” population by physician locations (zip code areas) and computing an initial physician-to-population ratio for each physician location (indicating its physician availability).
- (4) The updated table *DOCAVL* is “joined” to the table *TIME30* by physician locations (zip code areas).
- (5) Based on the updated *TIME30*, physician-to-population ratios are “summed” by population locations (census tracts), generating a new table (say, *TRTACC*). This sums up availability of physicians that are reachable from a residential location, and thus yields the accessibility A_i^F in Eq. (2).
- (6) Finally, the table *TRTACC* is “joined” to the population table *POPTRT* by census tracts for mapping and analysis.

In step (3), only those population tracts within the threshold travel time from a physician location enter the

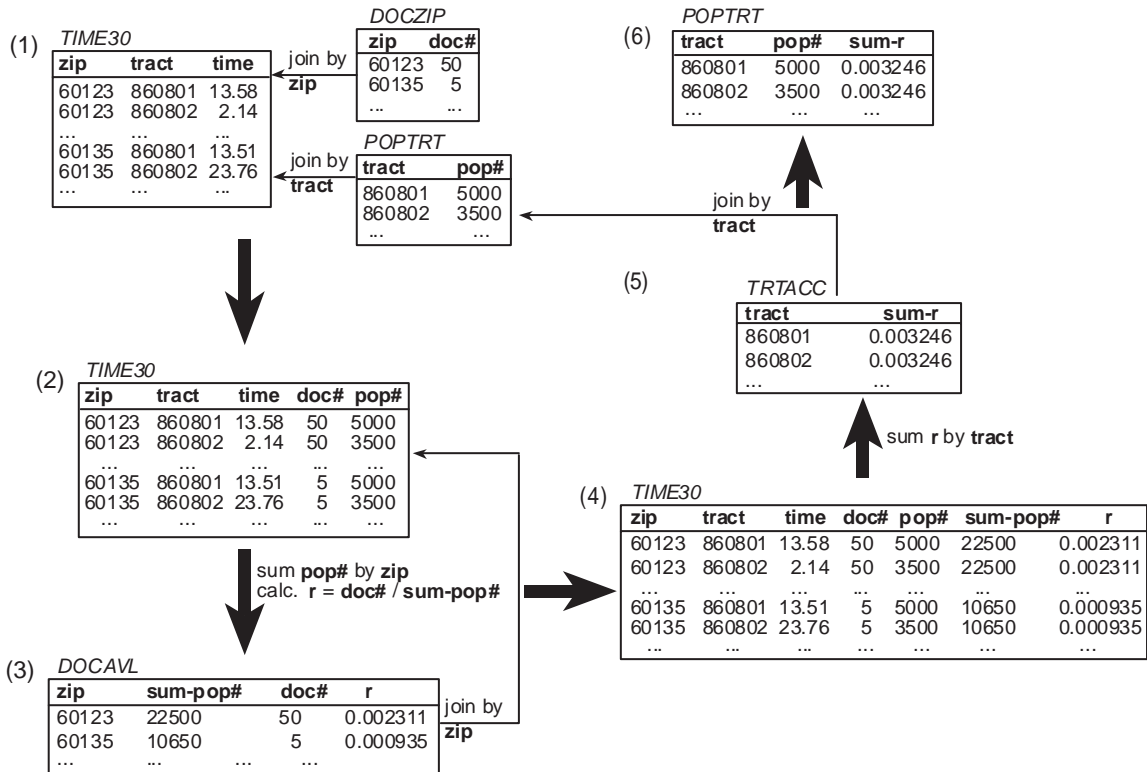

Fig. 2. Flow diagram of the two-step FCA method as implemented in ArcGIS.

computation of initial supply to-demand ratio, i.e., implementing Eq. (1); and in step (5) only ratios in those zip code areas (physician locations) within the threshold time from a population tract are summed up, i.e., implementing Eq. (2). Except for step (1), other steps may be also implemented in a statistical programming package such as SAS.

One may note that it draws an artificial line (say, 30 min) between an accessible and inaccessible physician. Physicians within that range are counted equally regardless of the actual travel time. A gravity model such as the one in Joseph and Bantock (1982) can be used to weigh a nearby physician higher than a remote one. Similar approaches have been used for evaluating job accessibility (e.g., Shen, 1998). The gravity-based accessibility A_i^G at location i can be written as

$$A_i^G = \sum_{j=1}^n \frac{S_j d_{ij}^{-\beta}}{V_i}, \text{ where } V_j = \sum_{k=1}^m P_k d_{kj}^{-\beta}, \quad (3)$$

where n and m indicate the total number of physician and population locations, respectively, β is the travel friction coefficient and all other variables are the same as in Eq. (2).

An earlier paper by Luo and Wang (2003) has proven that the two measures A_i^F and A_i^G essentially belong to the same theoretical framework. The only difference is that travel time impedance is dichotomous in Eq. (2) but continuous in Eq. (3).⁴ Three reasons make the two-step FCA method a more favorable choice. First, it is simple and can be easily adopted by state health departments. Secondly, it is intuitive as it compares supply (in the numerator) vs. demand (in the denominator). Defining the travel friction coefficient β in the gravity model is particularly troublesome since its value varies from place to place and also over time. Finally and perhaps more importantly, the FCA method is particularly suitable for identifying areas with low accessibility. An earlier study of sensitivity test using a range of β values revealed that the gravity-based method tended to conceal local pockets of poor accessibility (Luo and Wang, 2003).

Fig. 3 shows the variation of spatial accessibility measured by the two-step FCA method using a 30-min threshold time. Accessibility measures near the edge of the study area need to be interpreted with caution because residents may seek healthcare outside of the state—a problem that can be solved if data of physician

distributions in adjacent states are available and incorporated into the study. Two observations can be made from Fig. 3:

- (1) Areas with higher accessibility scores (better spatial access) are concentrated in urban areas, e.g., Chicago, Rockford, Springfield, Peoria, and Urbana-Champaign, whereas areas with lower accessibility scores (poorer spatial access) are mostly in rural areas.
- (2) This measure does not reveal impoverished inner-city communities that usually suffer from poor healthcare access.

Consolidating nonspatial factors by factor analysis

Population subgroups differ in terms of healthcare needs and accessibility according to their age, sex, social class, ethnicity, and other nonspatial characteristics. Based on a survey, Field (2000) compiled a list of factors that could affect healthcare access, and developed an index of relative advantage. Based on a literature review (including the DHHS guidelines for HPSA designation), this research considers the following variables, all obtainable from the 2000 Census data:

- (1) Demographic variables (such as age and sex) affecting health needs: *seniors with ages above 65, children with ages 0–4 and women with ages 15–44*. All three population groups are considered to have high needs for primary medical care services (e.g., US Department of Health and Human Services (DHHS), 1998; Meade and Earickson, 2000, p. 387). Without adequate weights for the three population groups, these three variables are simply summed up (assuming equal weights) to measure the *population with high needs*.
- (2) Socioeconomic status: *population in poverty, female-headed households, home ownership and median income*. Low socioeconomic status may incur important barriers to health access (e.g., Meade and Earickson, 2000, p. 387) and lead to ill health (e.g., Morris and Carstairs, 1991).
- (3) Environment: *households with an average of more than 1 person per room and housing units lack of basic amenities* (lacking complete plumbing or kitchen facilities). Overcrowding or poor living conditions may contribute to higher levels of ill health (e.g., Field, 2000, p. 315).
- (4) Linguistic barrier and service awareness: *nonwhite minorities, population without a high-school diploma and households linguistically isolated*. Minorities or lower educational attainment may be associated with lower service awareness (e.g., Field, 2000, p. 317), and linguistic isolation may create an important barrier to healthcare access (e.g., US

⁴ We may recode: (i) d_{ij} (or d_{kj}) = ∞ if d_{ij} (or d_{kj}) > d_0 ; and (ii) d_{ij} (or d_{kj}) = 1 if d_{ij} (or d_{kj}) $\leq d_0$, where d_0 is the threshold travel time. For any β in Eq. (3), we have: $d_{ij}^{-\beta}$ (or $d_{kj}^{-\beta}$) = 0 when d_{ij} (or d_{kj}) = ∞ ; and $d_{ij}^{-\beta}$ (or $d_{kj}^{-\beta}$) = 1 when d_{ij} (or d_{kj}) = 1. In case (i), S_j or P_k are excluded by being multiplied by zero; and in case (ii), S_j or P_k are included by being multiplied by one. Therefore, Eq. (3) is regressed to Eq. (2).

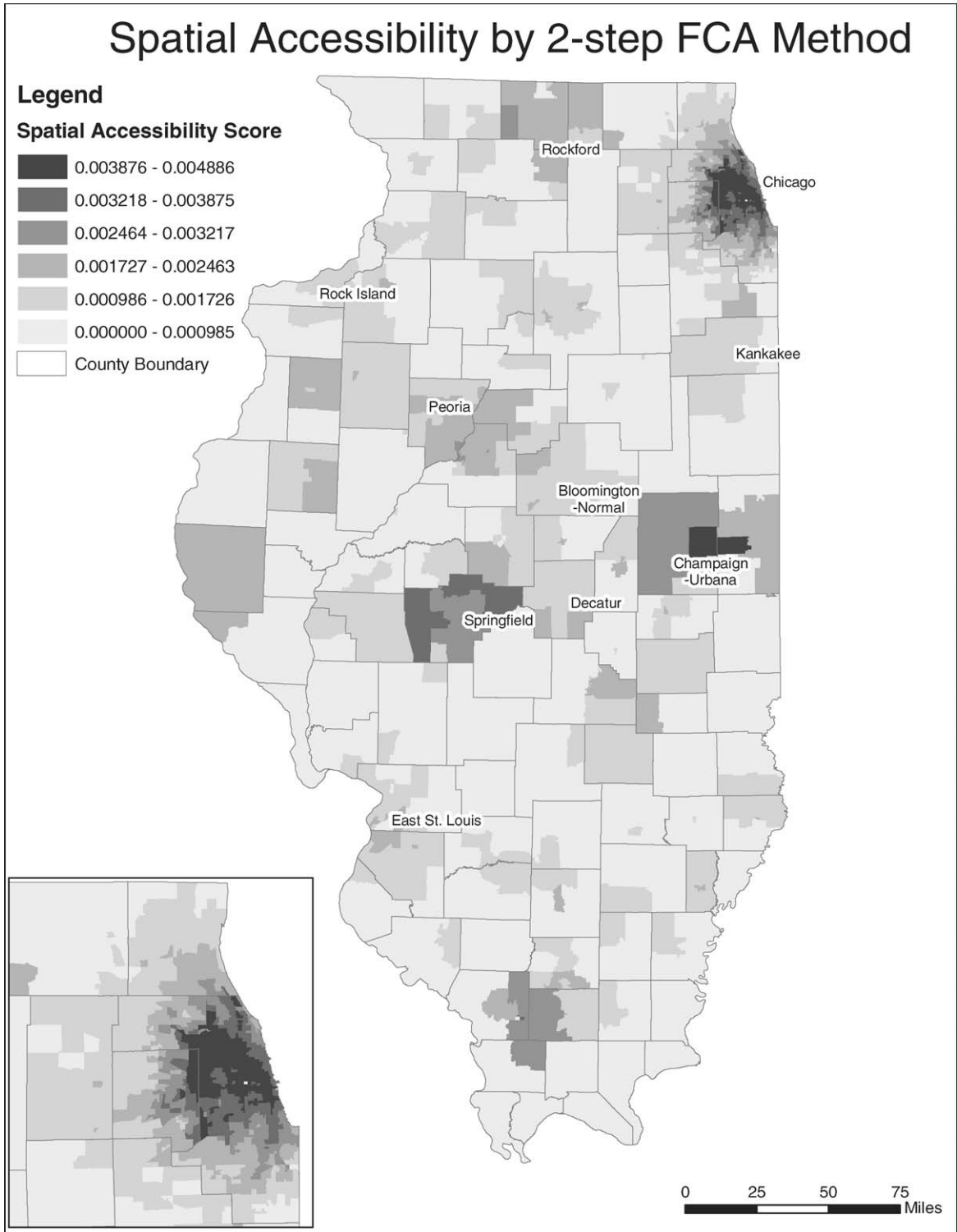

Fig. 3. Spatial accessibility to primary care in Illinois. Inset shows an enlargement of Chicago area.

Department of Health and Human Services (DHHS), 1998).

- (5) Transportation mobility: *households without vehicles*. People dependent solely on public transit may have less mobility and their accessibility to physicians is diminished to a great degree (e.g., Field, 2000).

All the above variables are measured in percentage except for the median income in dollars. Data are extracted from the Census 2000 Summary File 3 at the census tract level. Table 2 presents basic statistics of the above 11 variables. Note that the selection of primary care may also be affected by physicians affiliated with different insurance groups. However, the HPSA designation is to help government agencies channel limited resource to needy populations, whose access to governmental programs should not be limited by insurance status.

In Field (2000), all indicators were standardized according to a normal distribution, and then combined to produce a final composite score. The underlying assumption was an equal weight for each variable. The same assumption was implied in the MUA/P designation guidelines (US Department of Health and Human Services (DHHS), 2004). However, sociodemographic variables are often correlated and a simple aggregation of the indicators may not be appropriate. This research uses the FA to uncover underlying dimensions of nonspatial factors.

Principal components analysis (PCA) is often used as an initial step of FA to help determine how many factors to include in the analysis. However, “FA is both conceptually and mathematically very different from principal component[s] analysis” (Bailey and Gatrell, 1995, p. 225). In PCA, the same number of variables (components), but uncorrelated to each other, capture the same variance contained in the original data set. In other words, no information is lost in PCA. Table 3

shows that 11 components were used to capture the same information contained in the original 11 variables. The eigenvalues reported in Table 3 correspond to variances captured by individual components. That is to say, a larger eigenvalue indicates a component of more importance. The table ranks the components by proportions of the total variation summarized. The purpose of PCA is to show the relative importance of components based on their eigenvalues.

However, one may use only the first few components to capture a majority of the total variation. This leads to FA. In deciding the number of components to include, one has to make a tradeoff between the total variance explained (higher by including more components) and interpretability of factors (better with less components). Following a rule of thumb that only eigenvalues greater than 1 are important (Griffith and Amrhein, 1997, p. 169), three components (factors) are retained. The three components explain about three-quarters of the total variance. Unlike PCA, not all information contained in the original 11 variables is preserved in

Table 3
Eigenvalues from the principal components analysis

Component	Eigenvalue	Proportion	Cumulative
1	5.5944	0.5086	0.5086
2	1.6088	0.1463	0.6548
3	1.0138	0.0922	0.7470
4	0.8078	0.0734	0.8204
5	0.6013	0.0547	0.8751
6	0.4594	0.0418	0.9169
7	0.2544	0.0231	0.9400
8	0.2285	0.0208	0.9608
9	0.1622	0.0147	0.9755
10	0.1466	0.0133	0.9889
11	0.1226	0.0111	1.0000

Table 2
Basic statistics for the sociodemographic variables

Variable	Mean	Std. dev.	Minimum	Maximum
Population with high needs (%)	41.54	4.08	3.38	64.81
Population in poverty (%)	13.04	13.23	0.00	92.69
Female-headed households (%)	8.09	7.42	0.00	60.84
Home ownership (%)	64.53	24.22	0.00	100.00
Median income (\$)	46,869	22,191	2499	200,001
Households with > 1 person per room (%)	5.53	7.35	0.00	100.00
Housing units lack of basic amenities (%)	1.34	2.62	0.00	52.96
Nonwhite minorities (%)	29.92	32.42	0.00	100.00
Population w/o high-school diploma (%)	20.92	14.58	0.00	100.00
Households with linguistic isolation (%)	4.72	7.95	0.00	66.67
Households w/o vehicles (%)	14.03	15.31	0.00	100.00

Note: Number of observations (n) = 2952.

Table 4
Factor structure of nonspatial factors

	Socioeconomic disadvantages	Sociocultural barriers	High healthcare needs
Female-headed households (%)	<u>0.9089</u>	-0.0058	0.0504
Population in poverty (%)	<u>0.8662</u>	0.1642	0.2405
Nonwhite minorities (%)	<u>0.8481</u>	0.2153	-0.0153
Households w/o vehicles (%)	<u>0.8231</u>	0.1905	0.2699
Home ownership (%)	<u>-0.6686</u>	-0.3362	-0.3922
Housing units lack of basic amenities (%)	<u>0.4278</u>	0.2703	-0.0323
Households with linguistic isolation (%)	-0.0479	<u>0.9561</u>	0.0164
Households with > 1 person per room (%)	0.4464	<u>0.7966</u>	-0.0631
Population w/o high-school diploma (%)	0.5800	<u>0.6406</u>	0.1219
Population with high needs (%)	0.0316	-0.1050	<u>0.9186</u>
Median income (\$)	-0.5491	-0.2053	<u>-0.5605</u>
% of total variance explained	40.40	20.98	13.32
% of variance explained by the 3 factors	54.08	28.09	17.83

FA, but only a small fraction of the original information is lost. In order to better interpret and label different components, the popular Varimax rotation technique is used to maximize the loading of a variable on one factor and minimize the loadings on all others. Table 4 presents the rotated factor structure. The three factors are labeled to reflect major variables captured by each factor. Variables are reordered in Table 4 so that those with higher loadings on a factor are placed ahead of others.

There are two major advantages of using the FA method: (1) a large number of variables are consolidated into just a very few factors for easy interpretation and mapping; and (2) explained variances clearly indicate the relative importance of different factors and thus differentiate primary and secondary factors. The second feature is very important in designing procedures for identifying HPSAs.

Factor 1: socioeconomic disadvantages

This factor is by far the most important factor explaining 40.40% of total variance (i.e., accounting for 54.08% of the variance explained by the three factors). This factor captures six variables: female-headed households, population in poverty, nonwhite minorities, households without vehicles, home ownership, and housing units lack of basic amenities. Note that all loading coefficients are positive except for the home ownership variable because a lower percent of owner-occupied housing units is generally associated with a more deprived neighborhood. This factor is a comprehensive indicator of socioeconomic disadvantages. Fig. 4 shows the spatial distribution of socioeconomic disadvantages scores in Illinois. In contrast to Fig. 3, it shows that areas with high scores (poor access areas) are concentrated in the urban centers, whereas areas with

low scores (good access areas) are mostly in suburban and rural regions.

Factor 2: Sociocultural barriers

The second factor explains 20.98% of total variance (i.e., accounting for 28.09% of the variance explained by the three factors). It includes three variables: households with linguistic isolation, households with > 1 person per room, and population without high-school diploma. All three variables have positive loading coefficients, forming a comprehensive indicator of sociocultural barriers. As explained previously, linguistic isolation and lower educational attainment may be associated with lower service awareness, creating an important barrier to healthcare access. Immigrants tend to have less education and are also more likely to experience overcrowding in housing condition. Fig. 5 shows the distribution of sociocultural barriers scores in Illinois. Areas with high scores (poor access areas) are mostly located in the Chicago area and dispersed throughout its suburbs.

Factor 3: high healthcare needs

The third factor explains 13.32% of total variance (i.e., accounting for 17.83% of the variance explained by the three factors). It includes two variables: population with high needs and median income. Note that the income variable loads almost evenly between the first and third factors (both negative). Its loading on the first factor is understandable, and its loading on the third factor is less intuitive but not totally unexpected (i.e., areas with higher portions of seniors, children and women of child-bearing ages tend to have lower income). It is labeled “the factor of high healthcare needs”. See Fig. 6 for the distribution of

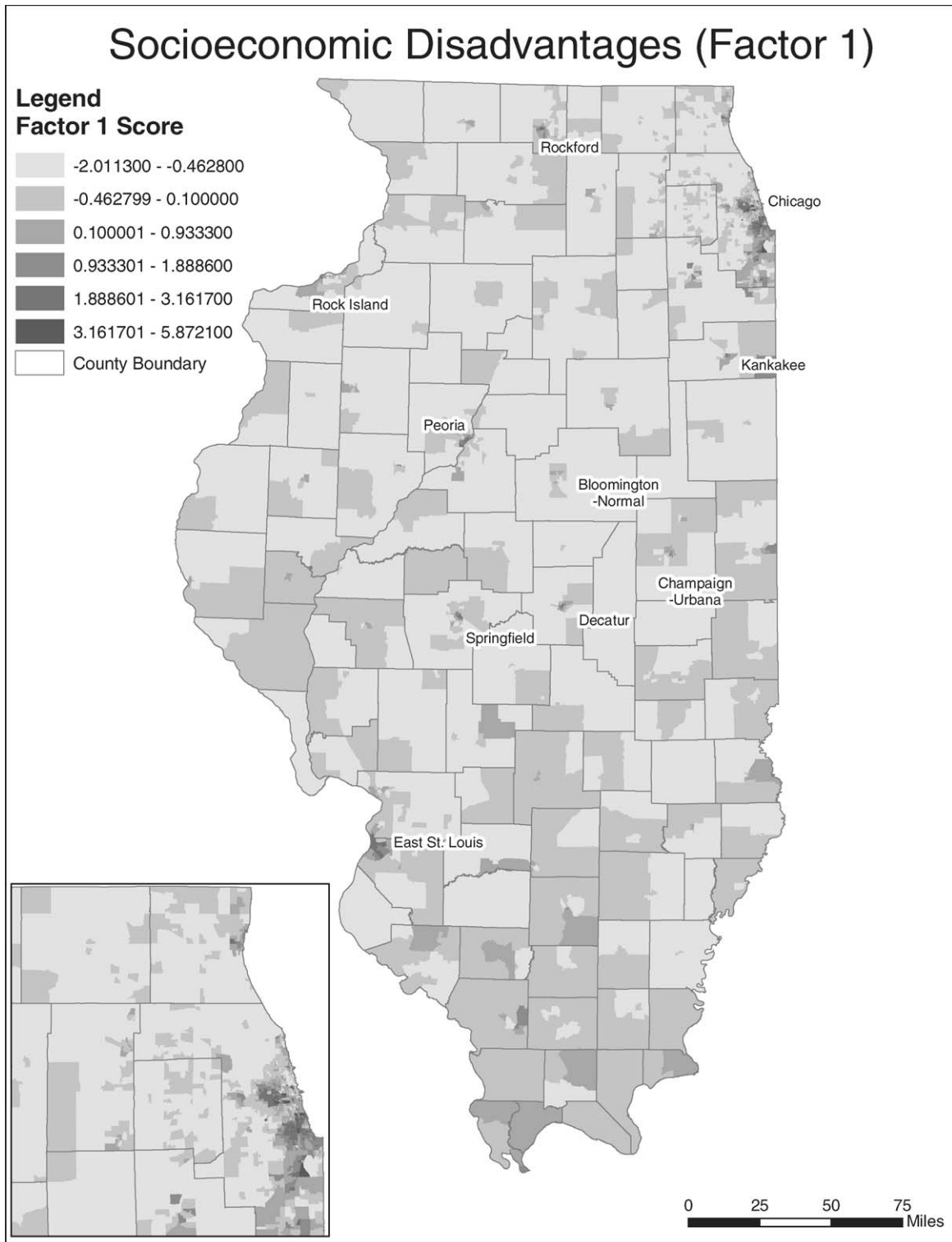

Fig. 4. The scores of socioeconomic disadvantages in Illinois. Inset shows an enlargement of Chicago area.

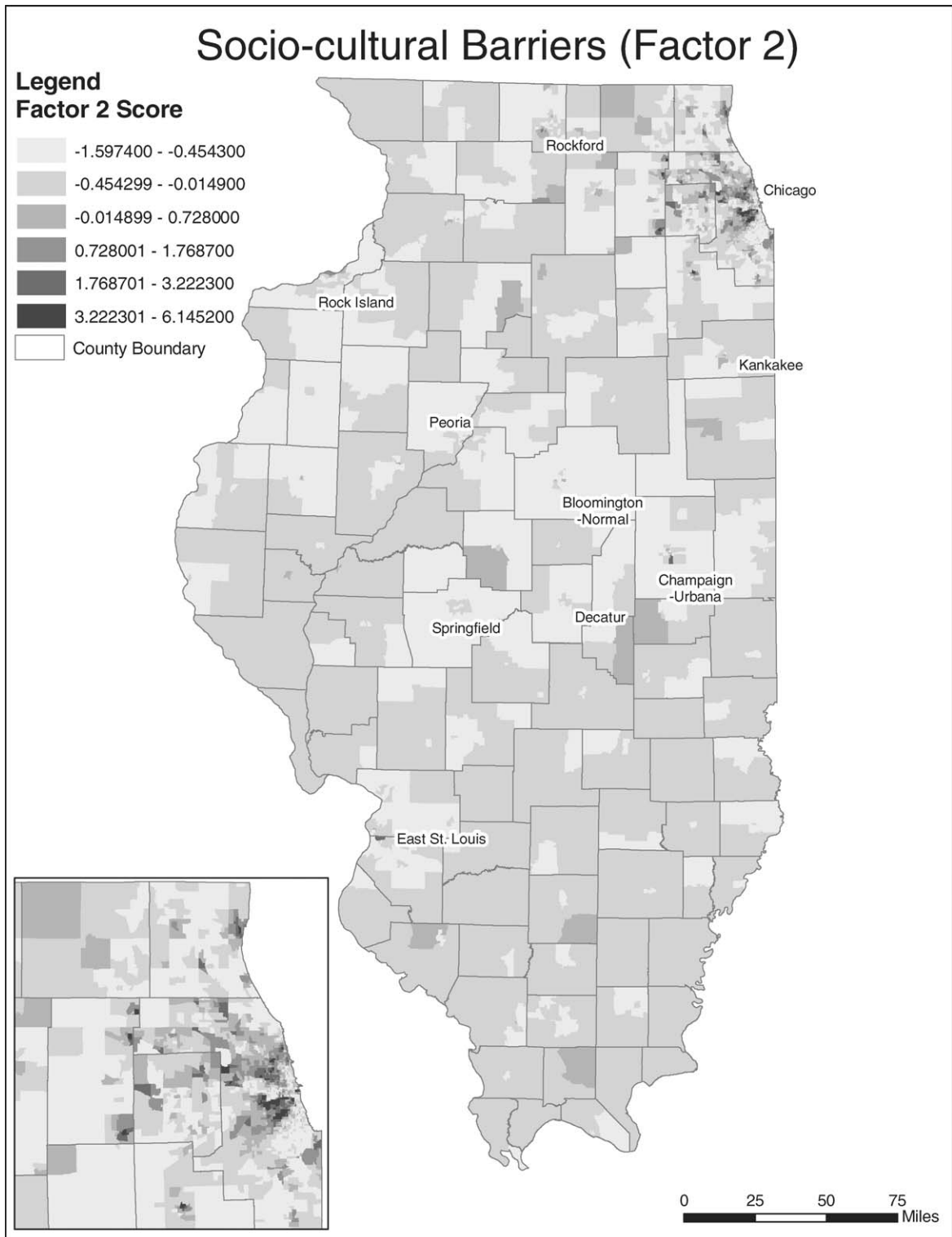

Fig. 5. The scores of sociocultural barriers in Illinois. Inset shows an enlargement of Chicago area.

high healthcare needs scores in Illinois. Unlike the other factors, the areas with high healthcare needs are dispersed throughout the state with no obvious geographic patterns.

Integrating spatial and nonspatial factors

The combination of one spatial accessibility measure and three nonspatial factors identified by the FA yields

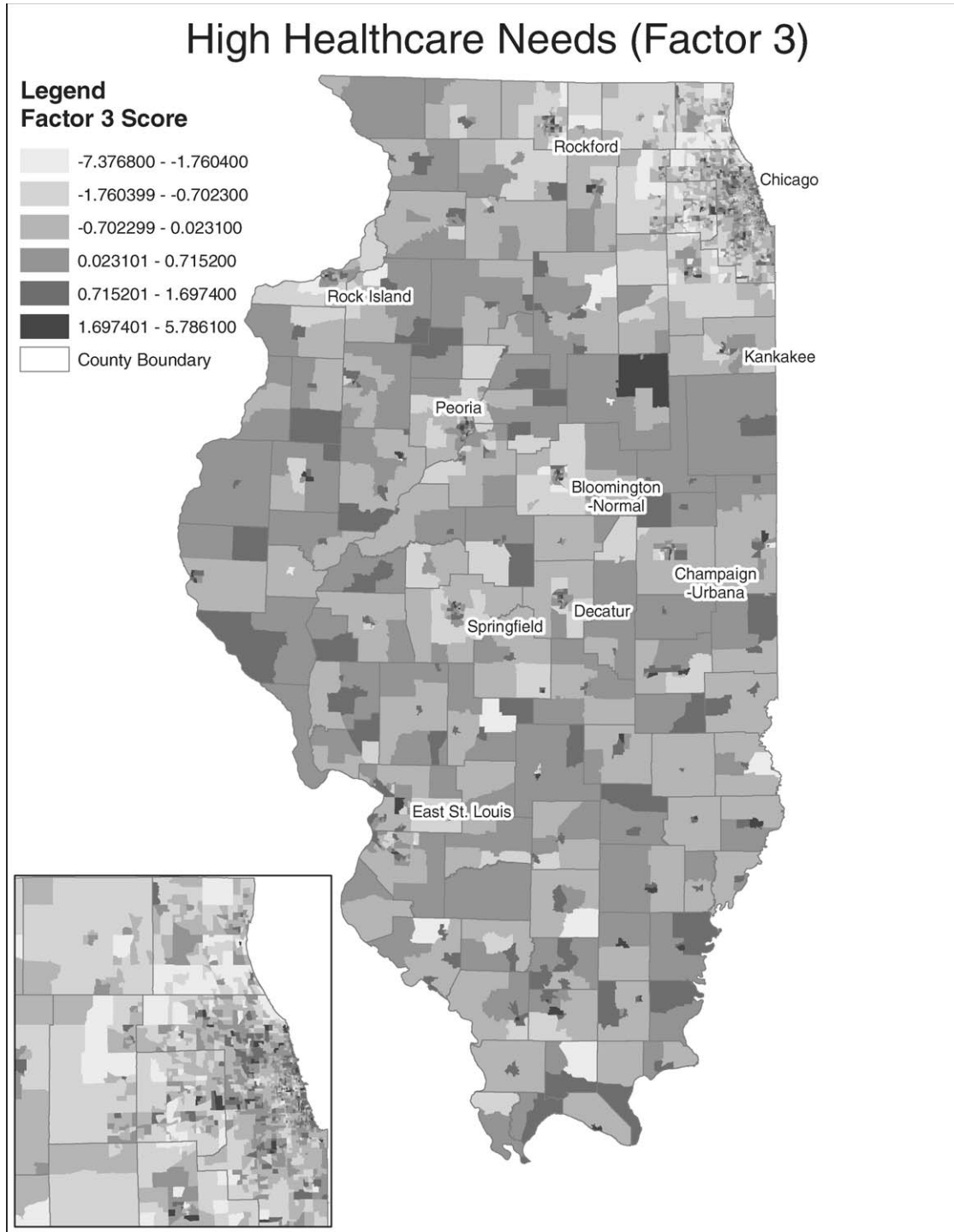

Fig. 6. The scores of high healthcare needs in Illinois. Inset shows an enlargement of Chicago area.

four factors to be considered for assessing healthcare access. By a careful examination, the third nonspatial factor of “high healthcare needs” merely reflects a weighting factor for the demand side of healthcare, and thus can be considered along with the spatial accessibility measure. In other words, one may assign larger weights to population subgroups with high healthcare needs and directly incorporate this factor into the spatial accessibility measure such as Eq. (2). However, such weights are hard to define and not available. This research uses the “spatial accessibility measure” as the primary indicator and the factor of “high healthcare needs” as the secondary indicator for identifying the first type of physician shortage areas (i.e., *geographic areas* as in the official HPSA designation guidelines). For identifying the second type of physician shortage areas (i.e., *population groups* as in the official HPSA designation guidelines), this research uses the factor of “socioeconomic disadvantages” as the primary indicator and the factor of “socio-cultural barriers” as the secondary indicator. A lower spatial accessibility value indicates poorer access whereas a higher score of any nonspatial factor corresponds to poorer access. See Table 5.

Specifically, the integrated approach identifies four kinds of shortage areas. For geographic areas,

- (1) tracts with the primary indicator (spatial accessibility) scores less than 1:3500 (as used in DHHS’s designation criteria) are considered shortage areas, regardless of their secondary indicator (high healthcare needs) scores—labeled “*areas of poor spatial access*”; and
- (2) tracts with the primary indicator scores greater than 1:3500 but less than 1:3000 are also considered as shortage areas if and only if their secondary indicator scores are one standard deviation above

its mean value—labeled “*areas of marginally poor spatial access with high needs*”.

- For the population groups,
- (3) tracts with the primary indicator (socioeconomic disadvantages) scores one standard deviation above its mean value are defined as shortage areas, regardless of their secondary indicator (socio-cultural barriers) scores—labeled “*disadvantaged population*”; and
 - (4) tracts with the primary indicator scores less than one standard deviation above its mean but greater than 3/4 standard deviations above its mean value are also considered as shortage areas if and only if their secondary indicator scores are one standard deviation above its mean value—labeled “*marginally disadvantaged population with sociocultural barriers*”.

According to a normal distribution, one standard deviation above the mean corresponds to about 12.1% of the sample whereas 3/4 standard deviations correspond to about 15.1%. The criteria were chosen after many experiments as the results were compared with officially designated HPSAs. The criteria generated an overall spatial pattern of HPSAs consistent with the official designation but with greater spatial details. The criteria may be adjusted according to the needs of individual states. In other words, the criteria may be tightened to reduce the number of qualified tracts or loosened to increase the number since all indicators are numerically continuous.

The results using the integrated approach for Illinois are shown in Fig. 7, where physician shortage areas are defined at the census tract level. The shortage areas based on population groups are mostly concentrated in urban areas. Their spatial extent may be limited but the

Table 5
Physician shortage areas identified by the integrated approach

HPSAs	Criteria		Tracts		Area		Population	
	Primary	Secondary	No.	%	km ²	%	No.	%
Geographic areas	Spatial acc. < 1/3500		63	2.13	18,684.14	12.80	215,367	1.73
	Spatial acc. ∈ [1/3500, 1/3000)	High need > mean + Std. Dev.	3	0.10	31.09	0.02	9591	0.08
Population groups	Socioecon disad. > mean + std		418	14.10	639.18	0.44	1,176,085	9.47
	Socioecon disad. ∈ [mean + 0.75std, mean + std)	Soc-cul barr. > mean + Std. dev.	17	0.57	7.49	0.01	49,734	0.40
Total			518	17.5	24,899.6	17.1	1,505,369	12.1

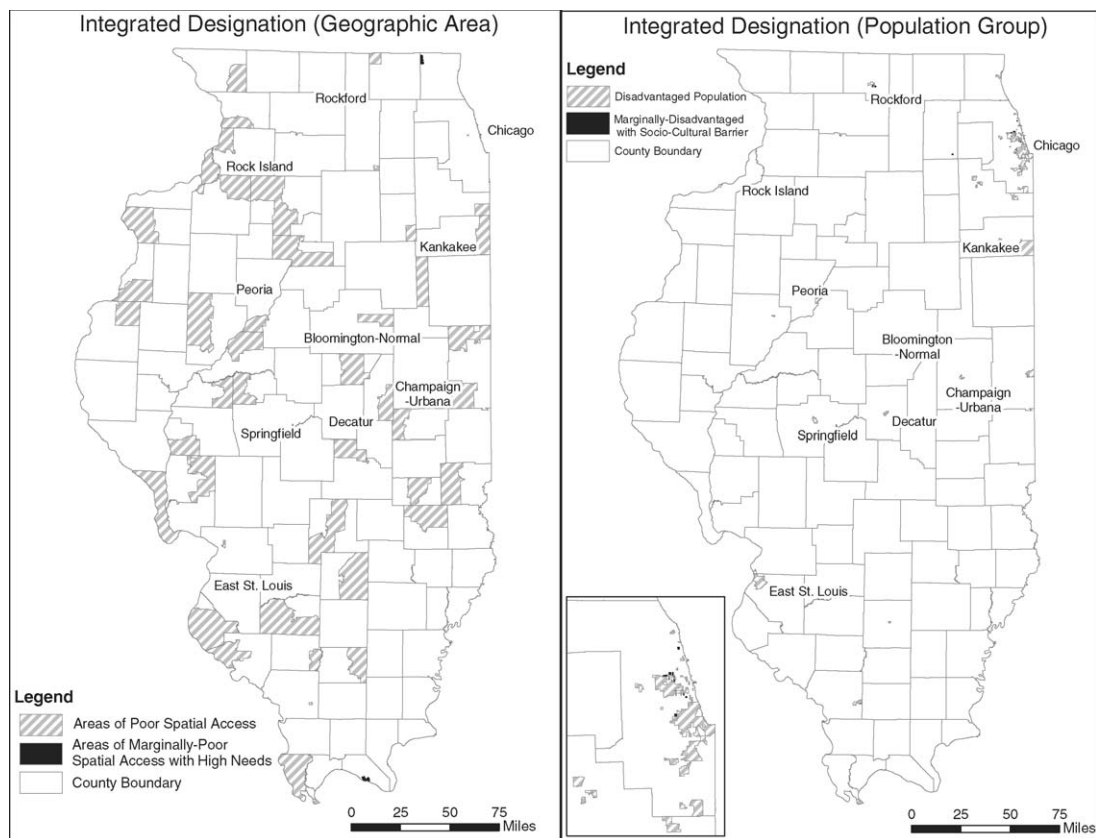

Fig. 7. Identified physician shortage areas in Illinois 2000 by the integrated approach. Inset shows an enlargement of Chicago area.

population they contain is significant (see Table 5). For administrative convenience, it may be overlaid with a county (or township) coverage to designate a whole county (township) as a shortage area if all (or almost all) census tracts in the county (township) are shortage areas. In fact, Illinois Department of Public Health has mostly used counties, county portions and political townships in the current HPSA designations (US Department of Health and Human Services (DHHS), 2002).

This integrated approach has at least three advantages. First, it defines physician shortage areas systematically, unlike the current designation process that often follows a case-by-case approach (based on an unpublished DHHS training manual for state health department personnel to prepare HPSA applications). Secondly, the quantitative criteria are consistent and precise with sound theoretical foundations corresponding to spatial and nonspatial factors. Finally, it is flexible and allows expansion (or contraction) of physician shortage areas to be designated according to available resources.

Summary

In summary, this research considers both spatial and nonspatial factors in examining accessibility to primary healthcare. The method is implemented and automated in a GIS environment, and applied to define HPSAs in Illinois using the 2000 Census and the 2000 primary care physician data. First, a two-step FCA method is implemented in GIS to measure spatial accessibility based on travel time. Second, the FA method is used to group various sociodemographic variables into three factors: (1) socioeconomic disadvantages, (2) socio-cultural barriers and (3) high healthcare needs. Finally, the spatial and nonspatial factors are integrated together to identify HPSAs: (1) using the spatial accessibility index as the primary indicator and the high healthcare needs score as the secondary indicator to identify the geographic-area type of HPSAs, and (2) using the socioeconomic disadvantages score as the primary indicator and the sociocultural barriers score as the secondary indicator to identify the population-group type of HPSAs. The integrated approach defines physician shortage areas at the census tract

level. For administrative convenience, the results may be overlaid with a township or county coverage and define a whole township or county as an HPSA if all or almost all census tracts within the larger unit are shortage areas. The method presented in this paper defines HPSAs in a systematic way using quantitative criteria that are consistent, precise and flexible. The method may help the DHHS and state health departments improve current practice of HPSA designation.

This research has demonstrated how GIS technologies can be used to enhance research in medical geography. First, GIS can be used to integrate spatial and nonspatial attribute information in one system and examine the relationship between them. Secondly, GIS can be used to map spatial patterns interactively and make easy adjustments according to user-defined criteria. Thirdly and perhaps most importantly, GIS can be used to analyze the spatial relationship and conduct complex computational tasks related to spatial data. GIS technologies are transforming the way we study medical geography, and will continue to contribute the advancement of health-related research.

Acknowledgements

This research is supported by the US Department of Health and Human Services, Agency for Healthcare Research and Quality, under Grant 1-R03-HS11764-01. Points of view or opinions in this article are those of the authors, and do not necessarily represent the official position or policies of the US Department of Health and Human Services.

References

- Bailey, T.C., Gatrell, A.C., 1995. *Interactive Spatial Data Analysis*. Longman Scientific & Technical, Harlow, England.
- Carr-Hill, R., Smith, P., Martin, S., Peacock, S., Hardman, G., 1994. Allocating resources to health authorities: development of method for small area analysis and the use of inpatient services. *British Medical Journal* 309, 1046–1049.
- Field, K., 2000. Measuring the need for primary health care: an index of relative disadvantage. *Applied Geography* 20, 305–332.
- General Accounting Office (GAO), 1995. Health care shortage areas: designation not a useful tool for directing resources to the underserved (GAO/HEHS-95-2000), Washington, DC.
- Griffith, D.A., Amrhein, C.G., 1997. *Multivariate Statistical Analysis for Geographers*. Prentice-Hall, Upper Saddle River, NJ.
- Hwang, H.-L., Rollow, J., 2000. Data processing procedures and methodology for estimating trip distances for the 1995 American Travel Survey (ATS). Report prepared by the Oak Ridge National Laboratory (ORNL/TM-2000/141).
- Joseph, A.E., Bantock, P.R., 1982. Measuring potential physical accessibility to general practitioners in rural areas: a method and case study. *Social Science & Medicine* 16, 85–90.
- Joseph, A.E., Phillips, D.R., 1984. *Accessibility and Utilization—Geographical Perspectives on Health Care Delivery*. Happer & Row Publishers, New York.
- Khan, A.A., 1992. An integrated approach to measuring potential spatial access to health care services. *Socio-Economic Planning Science* 26, 275–287.
- Knapp, K.K., Hardwick, K., 2000. The availability and distribution of dentists in rural ZIP codes and primary care health professional shortage areas (PC-HPSA) ZIP codes: comparison with primary care providers. *Journal of Public Health Dentistry* 60, 43–49.
- Lee, R.C., 1991. Current approaches to shortage area designation. *Journal of Rural Health* 7, 437–450.
- Lovett, A., Haynes, R., Sunnenberg, G., Gale, S., 2002. Car travel time and accessibility by bus to general practitioner services: a study using patient registers and GIS. *Social Science & Medicine* 55, 97–111.
- Luo, W., 2004. Using a GIS-based floating catchment method to assess areas with shortage of physicians. *Health and Place* 10, 1–11.
- Luo, W., Wang, F., 2003. Measures of spatial accessibility to healthcare in a GIS environment: synthesis and a case study in Chicago region. *Environment and Planning B: Planning and Design* 30, 865–884.
- Meade, S.M., Earickson, R.J., 2000. *Medical Geography* 2nd Edition. The Guilford Press, New York.
- Morris, R., Carstairs, V., 1991. Which deprivation? A comparison of selected deprivation indexes. *Journal of Public Health Medicine* 13, 318–326.
- Ng, E., Wilkins, R., Perras, A., 1993. How far is it to the nearest hospital? Calculating distances using the statistics Canada postal code conversion file. *Health Report* 5, 179–188.
- Parker, E.B., Campbell, J.L., 1998. Measuring access to primary medical care: some examples of the use of geographical information systems. *Health and Place* 4, 183–193.
- Peng, Z., 1997. The jobs-housing balance and urban commuting. *Urban Studies* 34, 1215–1235.
- Radke, J., Mu, L., 2000. Spatial decomposition, modeling and mapping service regions to predict access to social programs. *Geographic Information Sciences* 6, 105–112.
- Shen, Q., 1998. Location characteristics of inner-city neighborhoods and employment accessibility of low-income workers. *Environment and Planning B: Planning and Design* 25, 345–365.
- US Bureau of Census, 2001. *Census 2000 Summary File 1 (SF1)*, Illinois (on CD-ROM).
- US Bureau of Census, 2002. *Census 2000 Summary File 3 (SF3)*, Illinois, downloaded from the web site www.census.gov.
- US Department of Health and Human Services (DHHS), 1998. *Designation of medically underserved populations and*

- health professional shortage areas: proposed rule. Federal Register 63, 46537–46555.
- US Department of Health and Human Services (DHHS), 2002. Lists of designated primary medical care, mental health, and dental health professional shortage areas. Federal Register 67, 7739–7788.
- US Department of Health and Human Services (DHHS), 2004. Web site maintained by the health resources and services administration at <http://bphc.hrsa.gov/dsd> (last accessed January 20, 2004).
- Wang, F., Minor, W.W., 2002. Where the jobs are: employment access and crime patterns in Cleveland. *Annals of the Association of American Geographers* 92, 435–450.
- Wing, P., Reynolds, C., 1988. The availability of physician services: a geographic analysis. *Health Services Research* 23, 649–667.