



**For more information contact:**

**School of Nursing**

Northern Illinois University  
DeKalb, Illinois 60115-2894  
(815) 753-1231  
E-mail: [nursing@niu.edu](mailto:nursing@niu.edu)  
[www.chhs.niu.edu/nursing](http://www.chhs.niu.edu/nursing)

**Office of Admissions**

Northern Illinois University  
P.O. Box 3001  
DeKalb, Illinois 60115-2857  
(815) 753-0446  
E-mail: [admissions-info@niu.edu](mailto:admissions-info@niu.edu)  
[www.reg.niu.edu/admissn.htm](http://www.reg.niu.edu/admissn.htm)

**Testing Services**

Adams Hall 128  
Office: (815)753-1203  
E-mail: [testing@niu.edu](mailto:testing@niu.edu)  
Internet: [www.niu.edu/testing](http://www.niu.edu/testing)

**Electronic application:**

[www.reg.niu.edu/newadms/apply.htm](http://www.reg.niu.edu/newadms/apply.htm)

**NIU Home Page:**

[www.niu.edu](http://www.niu.edu)



**Bachelor of Science Degree with a Major in Nursing**

**BASIC PROGRAM**

Northern Illinois University's nursing program is a comprehensive major that prepares the professional nurse for leadership roles in patient care in the total spectrum of health care agencies and settings. Graduates are prepared to function with baccalaureate competencies in the delivery of nursing care, in assisting in the improvement of health care delivery systems, in utilizing the knowledge of the physical and social sciences as integral aspects of nursing, and in entering graduate programs that will further increase their nursing competencies and skills.

**Admission**

- Admission to the School of Nursing is **limited** and **competitive** and is based upon previous academic performance.
- Applications are accepted between September 1 and **February 15**.
- **Students new to the university** must apply through the Office of Admissions, specify their major as nursing, and must have submitted ALL application materials to the university by February 15 in order to be considered for admission to nursing.
- **Currently enrolled NIU students** must have submitted ALL application materials to the College of Health and Human Sciences Office, Wirtz Hall Room 227 or at the School of Nursing, Room 189, by February 15.
- **All applicants must successfully achieve a reading comprehension score in compliance with the School of Nursing standards.** If you have an ACT reading score of 24 or higher, you **must** submit an official copy of your ACT Test report. This report can be obtained by calling (319) 337-1313. If you plan to take the Accuplacer Exam, you **must** contact the NIU Office of Testing Services at (815) 753-1203 for Accuplacer Reading Exam information. Applications to the School of Nursing that do not include either an ACT reading score or an Accuplacer Reading Exam score will not be reviewed. Post graduates who hold baccalaureate or graduate degrees from an accredited U.S. college or university are exempt from this requirement. **Reading Scores must be submitted to the University on or before February 15.**

**Freshmen Applicants**

- All students with fewer than 24 post-secondary credit hours completed by the February 15 application deadline will be considered freshman applicants.
- Admission will be based on composite ACT score, high school rank, and reading comprehension score.

**Transfer Applicants**

- All Students with 24 or more post secondary semester hours of credit, whether continuing NIU students or new applicants to the university, are considered transfer students
- Applicants must have completed, by the **February 15** application deadline, a minimum of five of the prerequisite courses. Additionally, applicants **must achieve a minimum of a C or better** in all attempted prerequisite courses.
- Admission is competitive and will be based on the **applicant's prerequisite GPA and cumulative GPA** (including all transfer and NIU course work) and the **reading comprehension score**. Admitted students must have all prerequisite courses completed prior to beginning the nursing coursework and *may* begin in either the fall or spring semester as determined by the School of Nursing.

## ***Degree Requirements***

A minimum of 120 semester hours of course work is required to earn the Bachelor of Science degree with a major in nursing. In addition to general education and prerequisite course work, elective hours are needed to fulfill this requirement. Proficiency credit is available for some non-nursing courses.

## ***Prerequisite Courses outside Department (30-33 semester hours)***

Course work can be completed at Northern Illinois University or extra-departmental requirements can be met through transfer credit from most community colleges or universities. (See the current NIU *Undergraduate Catalog* for descriptions of course offerings.)

BIOS 104, General Biology (4)  
BIOS 213, Introduction to Bacteriology (3),  
or BIOS 313, Microbiology (4)  
BIOS 357, Human Anatomy and Physiology (5)  
CHEM 110, Chemistry (3), and CHEM 111, Chemistry  
Lab (1) or CHEM 210T, General Chemistry (3) and  
CHEM 212 General Chemistry Lab (1)  
ENGL 104, Rhetoric and Composition II (3)  
or ENGL 105, Rhetoric and Composition (3)  
PSYC 102, Introduction to Psychology (3)  
FCNS 201, Human Nutrition (3)  
FCNS 280, Human Development, the Family, and Society (3)  
or PSYC 225, Lifespan Development: Childhood through  
Adulthood (3)  
STAT 208, Basic Statistics (3)  
or STAT 301, Elementary Statistics (4)

**Note:** Nursing applicants must achieve a grade of C or better in all attempted nursing prerequisite courses.

## ***Requirements within Department (57 semester hours)***

NURS 300 Professional Nursing (2)  
NURS 301 Research in Nursing (3)  
NURS 306 Health Assessment (2)  
NURS 306A Health Assessment Lab (1)  
NURS 309 Alterations in Biological Systems (3)  
NURS 310A Clinical Development I (2)  
NURS 310T Fundamental Nursing (2)  
NURS 311 Mental Health Nursing (3)  
NURS 316 Adult Health Nursing I (3)  
NURS 317 Adult Health Nursing II (3)  
NURS 320 Clinical Development II (2)  
NURS 321 Parent-Child Health Nursing (3)  
NURS 322 Child Health Nursing (3)  
NURS 330 Clinical Development III (2)  
NURS 340 Clinical Development IV (2)  
NURS 360 Clinical Development V (2)  
NURS 401 Processes for Nursing Leadership (2)  
NURS 410T Clinical Development VI (2)  
NURS 420 Clinical Development VII (2)  
NURS 424 Community Health Nursing (3)  
NURS 429 Seminar in Professional Nursing (3)  
NURS 430 Clinical Development VIII (4)  
NURS 436 Pharmacology (3)

Note: The nursing courses require five (5) semesters to complete.

## **Drug Screen and Criminal Background Check**

All students are required to have a drug screen and a criminal background check. A Positive drug screen or criminal background check may result in the inability to complete the nursing program.

**For more information** about the undergraduate nursing program, contact the School of Nursing's undergraduate student services coordinator at (815) 753-6557.

**For application forms** and general information, contact:

Office of Admissions  
Northern Illinois University  
P.O. Box 3001  
DeKalb, Illinois 60115-2857  
(815) 753-0446

**I. UNIVERSITY GENERAL EDUCATION REQUIREMENTS (41 semester hours)**

A complete listing of general education courses and course descriptions can be found in the current *Undergraduate Catalog*.

Need: ENGL 103 and 104	Humanities - 9 semester hours
COMS 100 (Speech)	Science - (can be met by nursing requirements)
MATH 101 or 155 or 201 or 206 or 210 or 211 or 229	Social Science - 3 additional semester hours of credit Interdisciplinary - 3 semester hours of credit

**Transfer credit is available from most community colleges or universities.**

**II. NURSING EXTRADEPARTMENTAL REQUIREMENTS (30-33 semester hours)**

(23 semester hours are applicable towards general education credit)

ENGL 104 (Rhetoric and Composition II)	3 semester hours
BIOS 104 (General Biology)	4 semester hours with lab
BIOS 213 (Bacteriology)	3 semester hours with lab
or BIOS 313 (Microbiology)	4 semester hours with lab
BIOS 357 (Anatomy and Physiology)	5 semester hours with lab
CHEM 110 (Chemistry), and CHEM 111, (Chemistry Lab)	4 semester hours with required lab
or CHEM 210T (General Chemistry) and CHEM 212, (General Chemistry Lab)	4 semester hours with required lab
PSYC 102 (Introduction to Psychology)	3 semester hours
FCNS 280 (Human Development, the Family and Society)	3 semester hours
or PSYC 225 (Lifespan Development: Childhood through Adulthood)	3 semester hours
FCNS 201 (Human Nutrition)	3 semester hours
STAT 208 (Basic Statistics)	3 semester hours
or STAT 301 (Elementary Statistics)	4 semester hours

**Transfer credit is available from most community colleges or universities.**

**III. DEPARTMENTAL REQUIREMENTS (57 semester hours required)**

NURS 300	Professional Nursing	(2)
NURS 301	Research in Nursing	(3)
NURS 306	Health Assessment	(2)
NURS 306A	Health Assessment Lab	(1)
NURS 309	Alterations in Biological Systems	(3)
NURS 310A	Clinical Development I	(2)
NURS 310T	Fundamental Nursing	(2)
NURS 311	Mental Health Nursing	(3)
NURS 316	Adult Health Nursing I	(3)
NURS 317	Adult Health Nursing II	(3)
NURS 320	Clinical Development II	(2)
NURS 321	Parent Child Health Nursing	(3)
NURS 322	Child Health Nursing	(3)
NURS 330	Clinical Development III	(2)
NURS 340	Clinical Development IV	(2)
NURS 360	Clinical Development V	(2)
NURS 401	Processes for Nursing Leadership	(2)
NURS 410T	Clinical Development VI	(2)
NURS 420	Clinical Development VII	(2)
NURS 424	Community Health Nursing	(3)
NURS 429	Seminar in Professional Nursing	(3)
NURS 430	Clinical Development VIII	(4)
NURS 436	Pharmacology	(3)

**IV. GENERAL ELECTIVES**

A Bachelor of Science degree requires a total of 120 semester hours. Elective hours are needed to meet this requirement. A recommended elective is AHP 318 (Medical Terminology) 3 semester hours.

## EXAMPLE OF COURSE SEQUENCING

### *Basic Nursing Student*

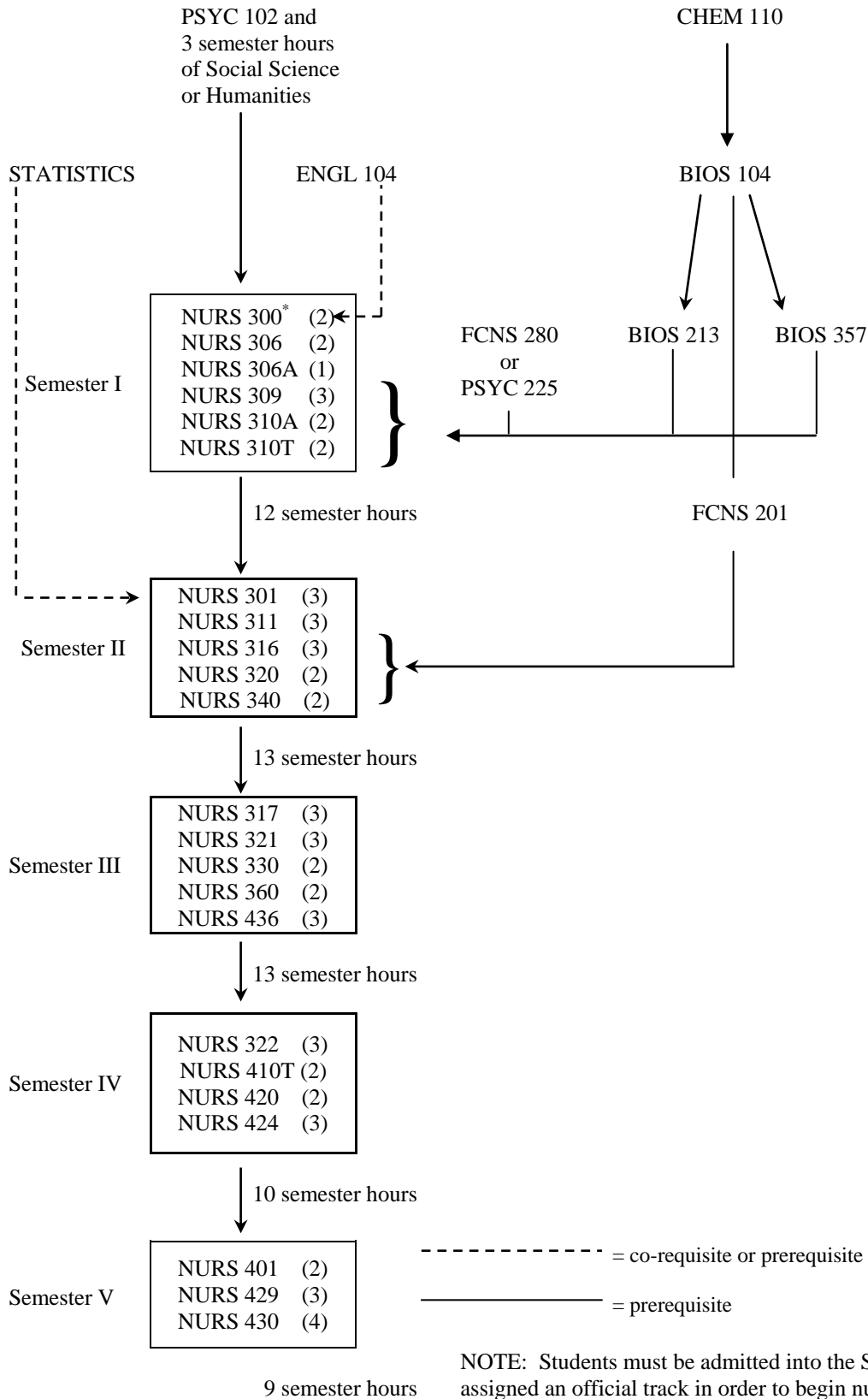

NOTE: Students must be admitted into the School of Nursing and be assigned an official track in order to begin nursing course work.

\*NURS 300 is open to nursing and non-nursing majors and may be taken prior to Semester I classes.

**SEMESTER I**

**NURS 310A.** CLINICAL DEVELOPMENT I (2). Exploration of processes used in nursing for the enhancement of health among culturally diverse clients. Emphasis on development of basic psychomotor and psychosocial skills in a laboratory and structured clinical setting. Individual transportation required. CRQ: NURS 300, NURS 306, NURS 306A, and NURS 309, or consent of school.

**SEMESTER II**

**NURS 320.** CLINICAL DEVELOPMENT II (2). Application of processes used in the enhancement of the health of culturally diverse individuals across the life span. Emphasis on the roles of the professional nurse as a beginning care giver and communicator in a structured clinical setting. Individual transportation required. PRQ: NURS 306, NURS 306A, NURS 309, NURS 310A, NURS 310T, with a grade of C or better, and FCNS 201. CRQ: NURS 316. Permit only.

**NURS 340.** CLINICAL DEVELOPMENT IV (2). Application of processes for the enhancement of the mental health of culturally diverse individuals, families, and groups in structured clinical settings. Continued emphasis on the roles of the professional nurse as beginning teacher and research consumer. Individual transportation required. PRQ: NURS 306, NURS 306A, NURS 309, NURS 310A, and NURS 310T, with a grade of C or better. CRQ: NURS 311 or consent of school. Permit only.

**SEMESTER III**

**NURS 330.** CLINICAL DEVELOPMENT III (2). Application of processes for the enhancement of the health of culturally diverse adults in structured clinical settings. Emphasis on the role of the professional nurse as beginning teacher and research consumer. Individual transportation required. PRQ: NURS 311, NURS 316, NURS 320, and NURS 340, with a grade of C or better. CRQ: NURS 317 or consent of school. Permit only.

**NURS 360.** CLINICAL DEVELOPMENT V (2). Integration of processes for the enhancement of the health of culturally diverse individuals in the childbearing family in diverse clinical settings. Emphasis on the role of the professional nurse as caregiver and advocate. Individual transportation required. PRQ: NURS 316, NURSE 320, 311 and NURS 340, with a grade of C or better. CRQ: NURS 321. Permit only.

**SEMESTER IV**

**NURS 410T.** CLINICAL DEVELOPMENT VI (2). Integration of processes for the enhancement of the health of culturally diverse individuals in the child rearing family in diverse clinical settings. Emphasis on the role of the professional nurse as caregiver and advocate. Individual transportation required. PRQ: NURS 317, NURS 321, NURS 330, NURS 360 and NURS 436, with a grade of C or better. CRQ: NURS 322. Permit only.

**NURS 420.** CLINICAL DEVELOPMENT VII (2). Integration of processes for the enhancement of the health of culturally diverse individuals, families, and aggregates or populations in community settings. Emphasis on the development of both collaborative and independent culturally competent practice. Individual transportation required. PRQ: NURS 317, NURS 321, NURS 330, NURS 360 and NURS 436, with a grade of C or better. CRQ: NURS 424 or consent of school. Permit only.

**SEMESTER V**

**NURS 430.** CLINICAL DEVELOPMENT VIII (4). Syntheses of processes for the enhancement of health across the lifespan. Emphasis on leadership in the management of care for culturally diverse individuals, families, and groups in a community, or hospital-based setting. Community-based placements focus on leadership roles such as program development, grant writing, administration, and/or case management. Hospital-based placements focus on direct patient care and leadership. Individual transportation required. PRQ: NURS 424, NURS 420, NURS 322, and NURS 410T, with a grade of C or better. CRQ: NURS 401. Permit only.