



Department of Mechanical Engineering

Undergraduate Program

2007-2008

Northern Illinois
University
DeKalb, IL

DEPARTMENT OF MECHANICAL ENGINEERING

NORTHERN ILLINOIS UNIVERSITY

Web: <http://www.ceet.niu.edu/depts/me/>

Phone: 815-753-9979

The mission of the Department of Mechanical Engineering is to provide an up-to-date, high-quality engineering education that meets current professional engineering standards and prepares competent engineers for local and global industry; to develop and/or apply engineering knowledge to address societal needs; and to provide quality professional and public services.

The Department of Mechanical Engineering offers an upper-division curriculum which leads to a Bachelor of Science (B.S.) in mechanical engineering. The curriculum is based on a strong foundation of fundamental courses in the pure sciences and engineering, and professional courses in mechanical engineering. The curriculum also provides a background in the design, analysis, development, and applications of both complete mechanical systems and a wide variety of individual system components in many different fields.

The B.S. program offered by the Department of Mechanical Engineering encompasses many areas, such as solid mechanics, dynamics and controls, fluid mechanics, thermodynamics, heat and mass transfer, energy conversion, and manufacturing. This background is strengthened and integrated through application in a sequence of broad engineering design and laboratory courses. Computers are used extensively throughout the curriculum, with emphasis on interactive computer-aided design, computer-aided manufacturing and simulation of engineering systems. The department has significant equipment for experimental investigations. Additionally, students may participate in an advanced computing curriculum track. Students participating in the track must take CSCI 240 and work on a computing/engineering project that spans four courses: MEE 381, MEE 481, MEE 482 and MEE 484. The Cooperative Education/Internship Program is also available to qualified students.

Department Requirements

Candidates for the Bachelor of Science degree in mechanical engineering must earn a minimum of 18 semester hours in humanities, arts, social sciences, and interdisciplinary studies. This requirement is described under “Special General Education Requirements for Electrical, Industrial, and Mechanical Engineering Majors” in the College of Engineering and Engineering Technology section of this catalog. Students must consult with their faculty advisers to determine appropriate courses.

All mechanical engineering students must have their schedule reviewed, approved, and signed by their faculty adviser each semester. Any deviation from an approved course schedule may delay graduation.

During the senior year, mechanical engineering majors complete a two-semester senior design project which is the capstone of the mechanical engineering curriculum.

Program Objectives of the Baccalaureate Degree in Mechanical Engineering

The program leading to the baccalaureate degree in mechanical engineering is designed to prepare students for successful careers in engineering and related fields by providing:

1. A balanced education in mechanical engineering that prepares students to apply analytical, computational, experimental and methodological tools to solve engineering problems;
2. A strong foundation in mathematics and physical sciences;
3. A broad and balanced general education in the humanities, arts, social sciences and interdisciplinary studies;
4. Sufficient training and development of skills for effective communication and team work;
5. A proper understanding of an engineer’s professional and ethical responsibilities in relation to engineering fields and society;
6. Recognition of the need for life-long learning.

Writing Across the Curriculum Courses

The Department of Mechanical Engineering recognizes that competence in technical writing is essential for engineers. To build upon the foundation for writing acquired in ENGL 103, Rhetoric and Composition I, and ENGL 104, Rhetoric and Composition II, or ENGL 105, Rhetoric and Composition, the Department of Mechanical Engineering has selected 300- and 400-level courses which are identified as writing intensive courses in the course description. These courses are MEE 390, MEE 425, MEE 481, MEE 482, and MEE 490. Each of these courses requires a significant technical writing component which will be reviewed by both the course instructor and a technical writing tutor.

Total Hours for B.S. in Mechanical Engineering: 134 (Major 107-108; General Education 27)

**BACHELOR OF SCIENCE IN MECHANICAL ENGINEERING
REQUIRED COURSES (134 Semester Hours)**

Requirements Outside Department (42 hrs)		Requirements In Department (65-66 hours)	
CHEM 210T	General Chemistry I (3)	MEE 210	Engineering Mechanics I (3)
CHEM 212	General Chemistry Laboratory I (1)	MEE 211	Engineering Mechanics II (3)
CSCI 240	Computer Programming in C++ (4)	MEE 212	Strength of Materials (3)
ELE 210	Engineering Circuit Analysis (4)	MEE 220	Mechanism Design (3)
ELE 210U	Engineering Circuit Laboratory Project (1)	MEE 270	Engineering Graphics (3)
ISYE 220	Engineering Economy (3)	MEE 321	Mechanical Vibrations I (3)
MATH 229	Calculus I (4)	MEE 322 / ELE 380	Dynamic Systems and Control I(3) / Controls Systems I (4)
MATH 230	Calculus II (4)	MEE 330	Materials Science (3)
MATH 232	Calculus III (4)	MEE 331	Manufacturing Processes (3)
MATH 336	Ordinary Differential Equations (3)	MEE 340	Fluid Mechanics (3)
STAT 350 / ISYE 335	Introduction to Probability and Statistics (3) / Statistics for Engineering (3)	MEE 350	Engineering Thermodynamics (3)
PHYS 253&U	Fundamentals of Physics I (4)	MEE 352	Heat Transfer (3)
PHYS 273&U	Fundamentals of Physics II (4)	MEE 380 / MEE 381	Computational Methods in Eng. Design (3) / Computational Methods & Programming in Eng. Design (3)
UEET 101	Introduction to Engineering (1)	MEE 390	Experimental Methods in ME I (3)
		MEE 430	Computer Aided Design and Manufacturing (3)
		MEE 452	Design Of Thermal Systems (3)
		MEE 470	Design of Machine Elements (3)
		MEE 481	Engineering Design Seminar (1)
		MEE 482	Senior Mech. Engineering Design Project (3)
		MEE 494	Mechanical Engineering Competency (1)
		MEE	Technical Electives (9). Selected from the following table.

Advanced Computational Track:

CSCI 240, MEE 381, MEE 481, MEE 482, MEE 484

A total of three electives with at least two from Group A. (9 hours, included in the 65-66 hours)			
Group A: Design Oriented Electives		Group B: Other Electives	
ISYE 450	Integrated Manufacturing Systems (3)	ISYE 430	Quality Control (3)
MEE 410	Intermediate Strength of Materials (3)	ISYE 431	Reliability Engineering (3)
MEE 422	Design of Robot Manipulators (3)	ISYE 451	Expert Systems in Manufacturing (3)
MEE 424	Machinery Vibration (3)	MEE 351	Applied Thermodynamics (3)
MEE 425	Design of Mobile Robots (3)	MEE 421	Dynamic Systems and Control II (3)
MEE 431	Composite Materials (3)	MEE 423	Mechanical Reliability (3)
MEE 451	Refrigeration and Air Conditioning (3)	MEE 480	Finite Element Methods (3)
MEE 453	Propulsion (3)	TECH 344	Materials & Processes in the Plastics industry (3)
MEE 484	Advanced Computing in ME (3)	TECH 345	Plastic Molding Processes (4)
MEE 490	Experimental Methods in ME II (3)		

General Education Requirements (27)		
COMS 100	Fundamentals of Oral Communication (3)	Electives in Humanities & Arts, Social Sciences and Interdisciplinary Studies (18)
ENGL 103	Rhetoric and Composition I (3)	
ENGL 104	Rhetoric and Composition II (3)	

NIU 4-year Study Plan For Mechanical Engineering (Effective Fall 2007)

Name: _____

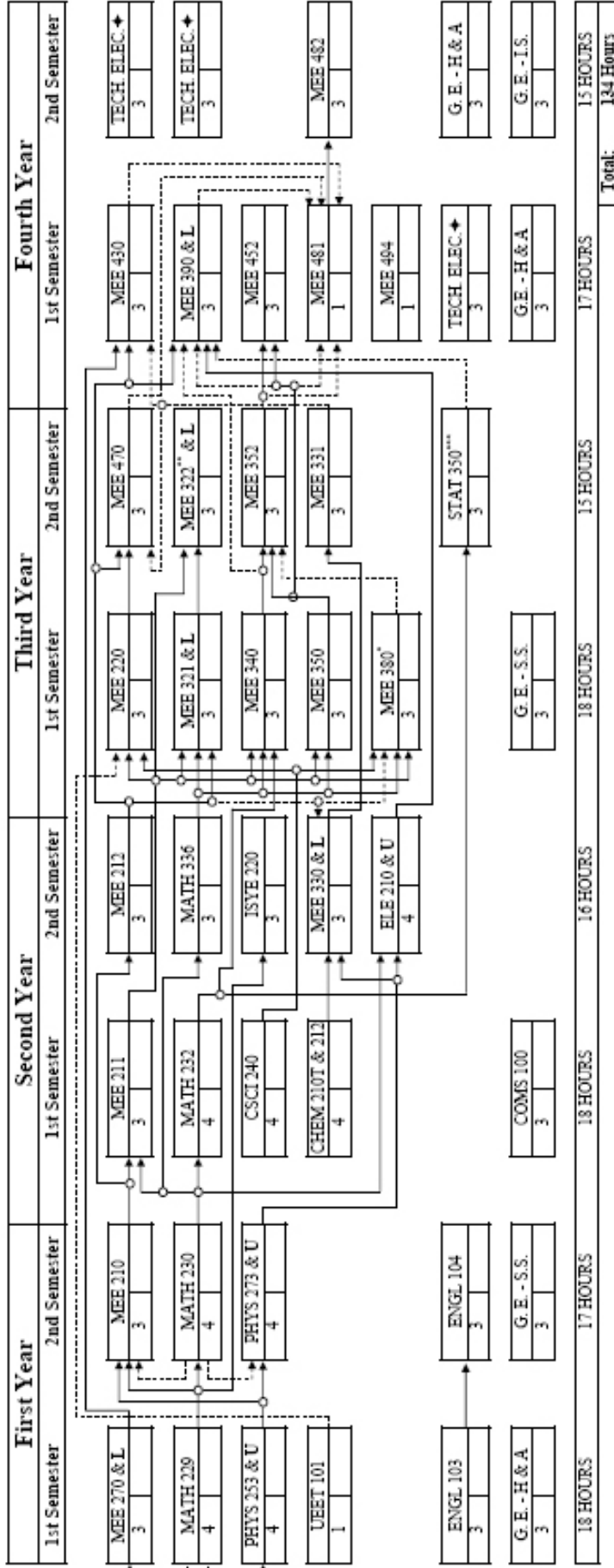

HUMANITIES AND ARTS (3 Courses)

College	Dept.	Course #	Title	Hours
LA & S				
V & PA				

At least one course must be taken in the College of Liberal Arts & Sciences and at least one course must be taken in the College of Visual & Performing Arts, with no more than 6 hours in any one department

SOCIAL SCIENCES (2 Courses)

Dept.	Course #	Title	Hours

INTERDISCIPLINARY STUDIES (1 Course)

Dept.	Course #	Title	Hours

The university general education requirements can be met by completing 9 hours in the Humanities and arts, 6 hours in social sciences, and 3 hours of interdisciplinary studies. Select course work from the general education requirements in the 2007-2008 Undergraduate Catalog, pp. 31-39. Of the 18 hours, do not take more than 9 hours in any one department.

Options

*	MEE 381 can be taken in lieu of MEE 380
**	ELE 380 can be taken in lieu of MEE 322
***	ISYE 335 can be taken in lieu of STAT 350

TECHNICAL ELECTIVES (3 Courses)

Dept.	Course #	Title	Hours

Group A: MEE 410, 422, 424, 425, 431, 451, 453, 484, 480 or ISYE 450

Choose One: MEE 351, 421, 423, 480, ISYE 430, 431, 451, TECH 344 or 345

* Tech. electives are not offered every semester. They should be taken whenever they are available.

MECHANICAL ENGINEERING (MEE) COURSE LIST

- 210. ENGINEERING MECHANICS I (3).** Principles of engineering mechanics; vector algebra, force systems, free-body diagrams, resultants, equilibrium, centroids and centers of gravity; application to trusses, frames, machines, and beams; moments of inertia; friction. PRQ: MATH 229 with grade of C or better; PHYS 253&U with grade of C or better. CRQ: MATH 230.
- 211. ENGINEERING MECHANICS II (3).** Kinematics of particles and rigid bodies; kinetics of particles and rigid bodies: force-mass-acceleration, work and energy, impulse and momentum. PRQ: MEE 210 and MATH 230 with grade of C or better.
- 212. STRENGTH OF MATERIALS (3).** Mechanics of deformable bodies with emphasis on principles of stress and strain; shear and bending moments; torsion, buckling; failure criteria and design concepts. PRQ: MEE 210.
- 220. MECHANISM DESIGN (3).** Introduction to kinematics and mechanism; mechanism design philosophy; displacement, velocity, and acceleration analysis; CAM design; gears; introduction to kinematic synthesis. Concepts of design supplemented by computer techniques of analysis. CRQ: UEET 101. PRQ: CSCI 240 and MEE 211.
- 230. MATERIALS AND MANUFACTURING PROCESSES (3).** Structures and properties of materials; testing and heat treatment of engineering materials; casting and forming processes; machining processes; welding and allied processes; processes and techniques related to manufacturing. Not counted for credit toward the major in mechanical engineering. PRQ: CHEM 210, CHEM 212, MATH 229 and PHYS 253.
- 270. ENGINEERING GRAPHICS (3).** Graphics in engineering and geometric constructions; orthographic projection and descriptive geometry with auxiliary views and revolution; pictorial presentation; developments; introduction to computer-aided drawing. CRQ: MATH 155 or MATH 229.
- 321. MECHANICAL VIBRATIONS I (3).** Oscillatory motion, free vibration of single degree freedom systems, harmonically excited vibration, vibration under general forcing conditions, two or more degrees of freedom systems, and generalized eigenvalue problems. In addition to lecture, the course has scheduled laboratory sessions. PRQ: MEE 211, MEE 212 and MATH 336.
- 322. DYNAMIC SYSTEMS AND CONTROL I (3).** Introduction to simple harmonic motion, damping, resonance, and multiple degree of freedom systems. Modeling of mechanical systems and their transfer functions, feedback control, and introduction to Root-locus and Bode design. In addition to lecture, the course has scheduled laboratory sessions. PRQ: MEE 211, and ELE 315 or MEE 321.
- 330. MATERIALS SCIENCE (3).** Introduction to the relation between processing, structure, properties, and performance of metallic, ceramic, and polymeric engineering materials. In addition to lecture, the course has scheduled laboratory sessions. PRQ: CHEM 210T and CHEM 212 with grade of C or better and PHYS 273&U with grade of C or better. CRQ: MEE 212 .
- 331. MANUFACTURING PROCESSES (3).** Mechanical properties of materials; metallurgical control of mechanical properties; casting and forming processes; machining processes; welding and allied processes; processes and techniques related to manufacturing. PRQ: MEE 330.
- 340. FLUID MECHANICS (3).** Introduction and fundamentals of fluid statics, integral form and control volume analysis, differential analysis and potential flow, incompressible viscous internal and external flow, and compressible flow. PRQ: MEE 211, MATH232, and MATH 336.
- 350. ENGINEERING THERMODYNAMICS (3).** Principles of thermal energy conversion; properties of pure substance; work and heat; first law of thermodynamics, control volume, steady state and steady flow process, uniform state and uniform flow process; second law of thermodynamics, entropy, availability; power and refrigeration cycles. PRQ: MEE 211 and MATH 336.
- 351. APPLIED THERMODYNAMICS (3).** Thermodynamic cycles and processes; generalized thermodynamic relationships; mixtures and solutions; chemical reaction; phase and chemical equilibrium; nozzles, diffusers, and flowmeters. PRQ: MEE 350.
- 352. HEAT TRANSFER (3).** Basic laws of heat transfer; steady state heat conduction, heat generation, and extended surfaces; unsteady and multidimensional conduction; analytical, graphical, and numerical solutions; external and internal forced convection; boundary layer theory; free convection, similarity and integral solutions; radiation properties and exchange between black and nonblack surfaces; numerical solutions techniques. Design projects required. PRQ: MEE 340 and MEE 350. CRQ: MEE 380 or MEE 381.
- 380. COMPUTATIONAL METHODS IN ENGINEERING DESIGN (3).** Number representation, root finding, systems of linear equations and matrices, eigenvalues and eigenvectors, curve fitting, integration and differentiation, finite difference methods and linear programming. PRQ: CSCI 240, MATH 336 and MEE 211. CRQ: MEE 212.
- 381. COMPUTATIONAL METHODS & PROGRAMMING IN ENGINEERING DESIGN (3).** Number representation, root finding, matrix inversion/factorization, eigenvalues/eigenvectors, minimization, integration of functions, and ODEs. Emphasis on programming style and technique in the C++ language, including object-based programming, computational efficiency, code reuse, and scalability. PRQ: CSCI 240 and MATH 336.

390. EXPERIMENTAL METHODS IN MECHANICAL ENGINEERING I (3). Basic concepts of measurement methods and planning and documenting experiments. Typical sensors, transducers, and measurement system behavior. Data sampling and computerized data acquisition systems. Statistical methods and uncertainty analysis applied to data reduction. Laboratory experiments with measurement of selected material properties and solid-mechanical and fluid/thermal quantities. A writing-intensive course. PRQ: MEE 212 and ELE 210&U. CRQ: MEE 340, MEE 350, and STAT 350 or IENG 335.

410. INTERMEDIATE MECHANICS OF MATERIALS (3). Buckling, unsymmetric bending, transverse loading, curved beams, thick-walled cylinders and rotating disks, torsion of thin-walled tubes, contact stresses, plastic behavior, strain energy and Castigliano's theorem, strength theories and design equations, fatigue, and fracture. PRQ: MEE 212, and MATH 336. CRQ: MEE 380 or MEE 381 or consent of department.

421. DYNAMIC SYSTEMS AND CONTROL II (3). Concepts of linear system theory; modal analysis, Lagrange's Equations, approximate numerical methods for solving vibration problems. Root-locus and frequency response design. State-space analysis. Case studies in control system design. PRQ: MEE 322 or ELE 380, or consent of department.

422. DESIGN OF ROBOT MANIPULATORS (3). Mathematics, programming, and control in the design of robot manipulators. Includes topics on kinematics, differential relationships and dynamics, motion trajectories, and control algorithms. PRQ: MEE 211 and MATH 336, or consent of department.

423. MECHANICAL RELIABILITY (3). Basic probability, statistics, and reliability concepts applicable to mechanical systems. Probabilistic treatment of loads, stress, strength, safety indices, and fatigue. Mechanical equipment reliability; wear-out; reliability-based design, testing, and maintenance. PRQ: MEE 212. CRQ: MEE 470 or consent of department.

424. MACHINERY VIBRATION (3). Machinery vibration analysis: signature analysis in time and frequency domains, fault detection, diagnosis, and correction; instrumentation; case studies; machine monitoring programs. PRQ: MEE 322. CRQ: MEE 470.

425. DESIGN OF MOBILE ROBOTS (3). Configuration and architecture design. Position estimation, planning, and control. Perception and learning. Group capstone project in the design and development of a mobile robot. Lecture, discussion, case studies of mobile robot design. A writing-intensive course. PRQ: MEE 211 or TECH 375, or consent of department.

426. MECHATRONICS SYSTEM DESIGN (3). Use of computers embedded in mechanical systems, microcontrollers, real-time software, analog and digital world, sensors and actuators interfacing, electronics for mechatronics, measures of system performance, state transition logic and multitasking, mechatronics system design problems, advanced concepts and case studies of mechanical systems with embedded electronics. PRQ: CSCI 240, ELE 210, and ELE 380 or MEE 322, or consent of department.

430. COMPUTER-AIDED DESIGN AND MANUFACTURING (3). Computers for CAD/CAM; methodology in CAD, geometry description, geometric modeling, geometry construction by programming, applications of finite element method. NC part programming with G-code and APT, machine tool path verification with advanced software. PRQ: MEE 212, MEE 270&L, and either PRQ: MEE 230 or CRQ: MEE 331, or consent of department.

431. COMPOSITE MATERIALS (3). Fiber and matrix properties, micromechanical and macromechanical behavior of lamina, lamination theory. PRQ: MEE 212, MEE 330, and MEE 380 or MEE 381, or consent of department.

451. REFRIGERATION AND AIR CONDITIONING (3). Refrigerants; vapor compression and absorption refrigeration systems; cryogenics; psychrometrics and humidity measurements; extended surface coils and transfer processes between moist air and water; solar radiation and heating and cooling loads of buildings and structures. PRQ: MEE 350 and MEE 352.

452. DESIGN OF THERMAL SYSTEMS (3). Application of principles of fluid mechanics, heat transfer, and thermodynamics in the component design of thermal systems. Examples are drawn from power generations, environmental control, and industrial processes. Students work on group projects for integration of these components in the design of thermal systems. PRQ: MEE 350 and MEE 352.

453. PROPULSION (3). Aerodynamics and thermodynamics of gas turbine airbreathing and rocket engines; quasi-one-dimensional flow; ideal and real cycle analysis; component performance; engine operating off-design characteristics. PRQ: MEE 340 and MEE 350.

470. DESIGN OF MACHINE ELEMENTS (3). Fatigue analysis; design of screws, fasteners, and connections; design of welded, brazed, and bonded joints; mechanical springs; bearings; gears; shafts; design of clutches, brakes, couplings, and flywheels; flexible mechanical elements. PRQ: MEE 212 and MEE 220. CRQ: MEE 331 or consent of department.

480. FINITE ELEMENT METHODS (3). Methods of weighted residual; variational methods of approximation; variational formulation; shape functions; finite element formulation; error analysis; computer implementation; and applications to solid mechanics, dynamics, vibration, fluid mechanics, and heat transfer. PRQ: MEE 322, MEE 352, and MEE 380 or MEE 381, or consent of department.

481. ENGINEERING DESIGN SEMINAR (1). Complete preparation of an engineering system design or project proposal covering problem identification, conceptual design, and the schedule of work required to carry out the project. (Projects are carried out in MEE 482). Concurrent seminar of methodology, standards and safety codes, professional ethics, decision making, and design evaluations. A writing-intensive course. CRQ: MEE 350, MEE 352, MEE 390&L, MEE 430 and MEE 470.

482. SENIOR MECHANICAL ENGINEERING DESIGN PROJECT (3). Special design project under individual supervision of the instructor. A writing-intensive course. PRQ: MEE 481.

484. ADVANCED COMPUTING IN MECHANICAL ENGINEERING (3). Project-based course which combines engineering science with advanced computing, including a practical introduction to object-oriented programming, data structures, and other topics that facilitate programming-in-the-large. Students write a substantial portion of a vehicle dynamics simulation. PRQ: MEE 381 or consent of department. Recommended CRQ: MEE 481.

490. EXPERIMENTAL METHODS IN MECHANICAL ENGINEERING II (3). Experimental design; statistical analysis of data; computerized data acquisition and reduction; experiments on signature analysis, fluid flow, heat transfer, material properties, and vibrations; individual experimental design projects. A writing-intensive course. PRQ: MEE 390 or consent of department.

494. MECHANICAL ENGINEERING COMPETENCY (1). Review of fundamental concepts and problem solving in mathematics, physics, chemistry, electrical circuits, statics, dynamics, strength of materials, material science, fluid mechanics, thermodynamics, heat transfer, control, and computer programming. Grades based on performance on a national standardized examination. PRQ: Senior status.

497. INDEPENDENT STUDY (1-3). Independent pursuit of problems in mechanical engineering under faculty supervision. Written report required. May be repeated to a maximum of 3 semester hours. PRQ: Consent of department.

498. SPECIAL TOPICS (1-3). Topics not included in regular courses. May be repeated to a maximum of 3 semester hours. PRQ: Consent of department.